

SPLASH32

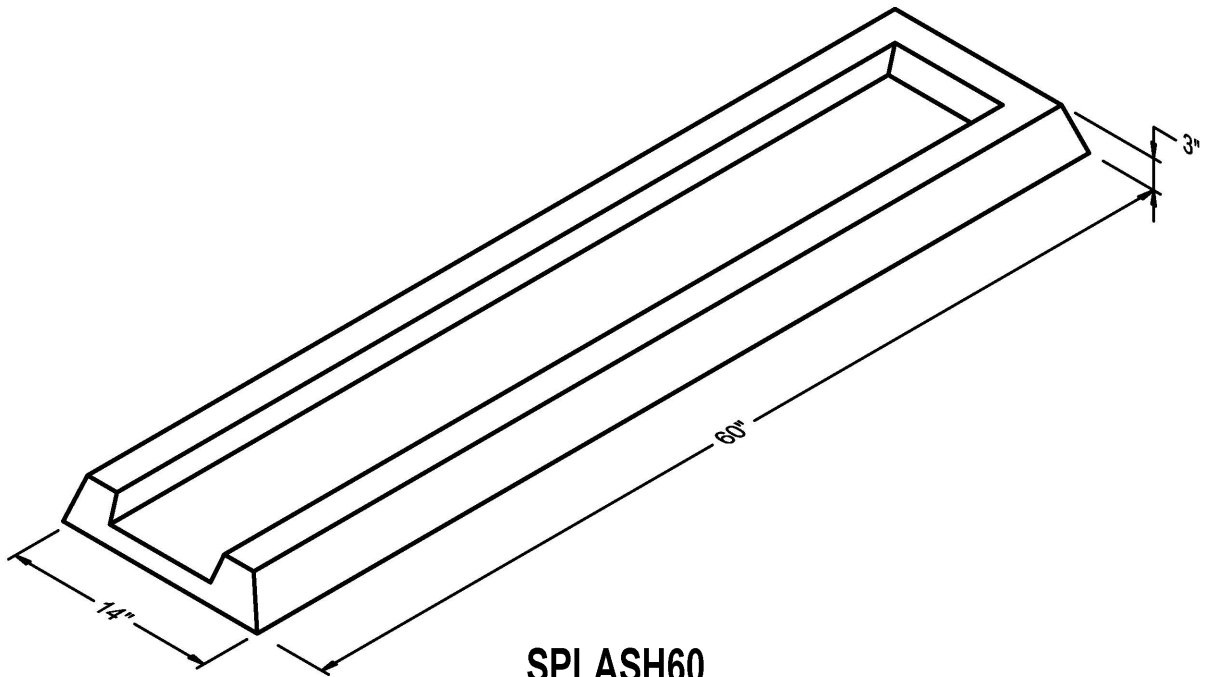

SPLASH60