

PLAN VIEW

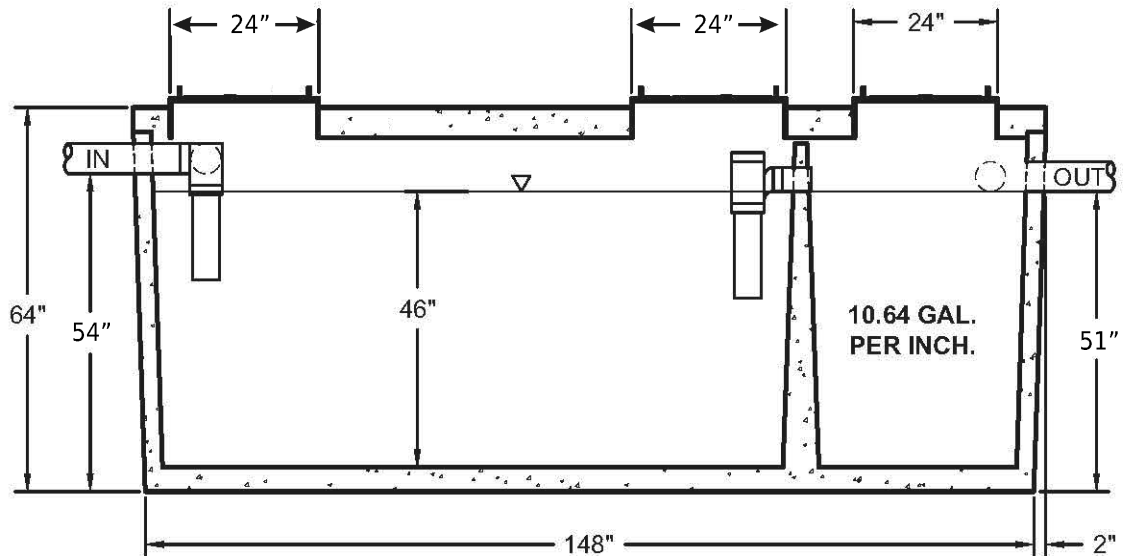

SECTION VIEW

DESIGN NOTES

1. Concrete: 4,500 psi @ 28 days
2. Meets or Exceeds State DEQ and Local Requirements
3. 1-Piece Construction with Mastic Sealant - ASTM C990
4. Construction: Light Traffic Loading Maximum Cover 5'
5. Tank Requires PVC Tee on Inlet and Effluent Filter at Outlet

SCALE: 3/8" = 1'-0"